

ELEMENTE DE LEGATURA GRAD 80 IN CONFORMITATE CU EN 1677-2

CARLIG CU OCHI SI SIGURANTA MODEL 100

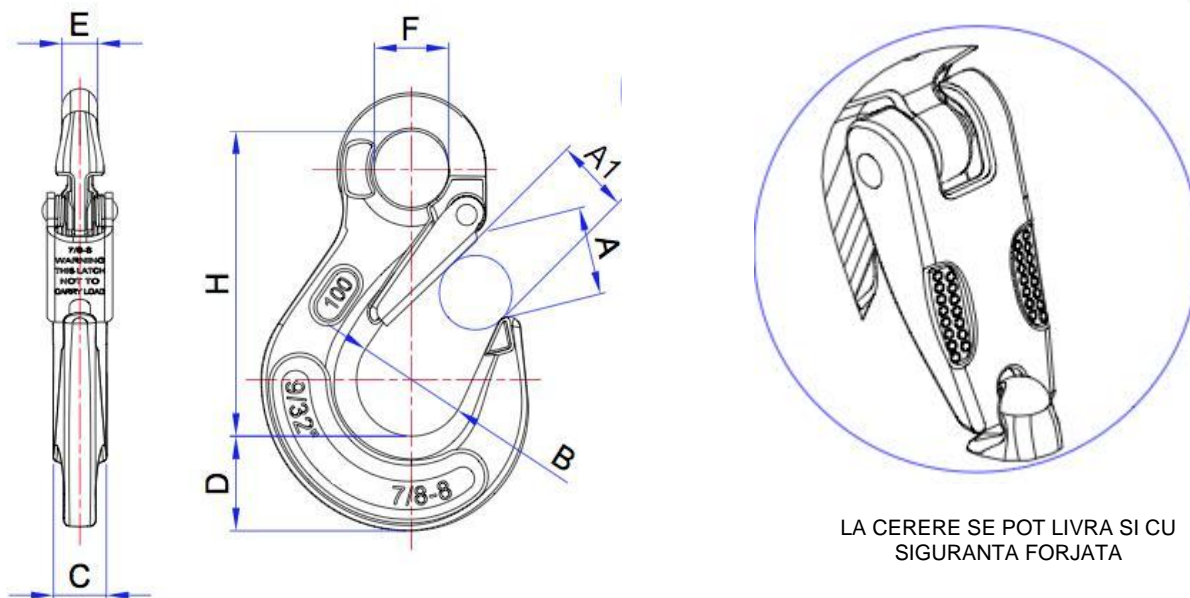

Cod nr.	W.L.L. Tone	LANT mm	DIMENSIUNI								GREUTATE kg
			A	A1	B	C	D	E	F	H	
			mm	mm	mm	mm	mm	mm	mm	mm	
41.23.08.0000	2	7/8 - 8	29	24	36	17	30	12	24	94	0,60
41.23.10.0000	3,15	10 - 8	40	32	45	24	35	16	32	122	0,95
41.23.13.0000	5,3	13 - 8	48	40	54	30	43	18	38	152	2,00



- Otel Clasa 8 : Coeficient de siguranta 4
- Culoare: **Rosu**

**GO BACK**